

=25°C (unless otherwise specified)

		=25°C =100°C =25°C		
		=25°C	=25°C	±
				°C
				°C/W °C/W

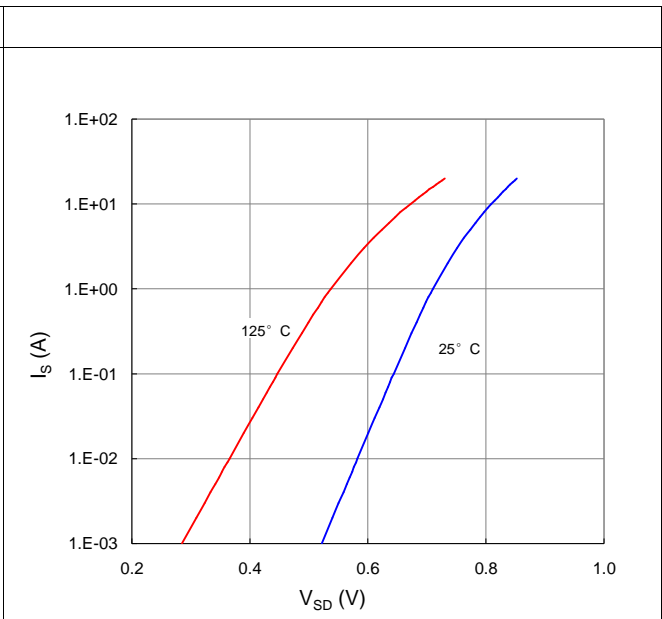

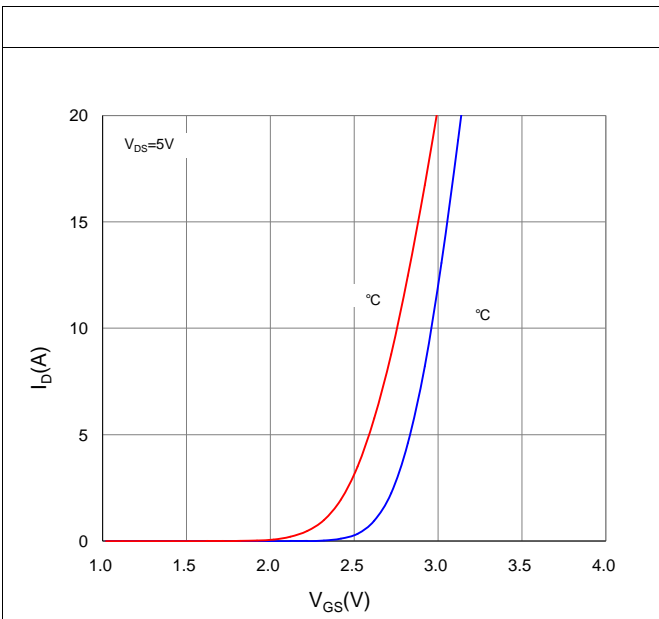

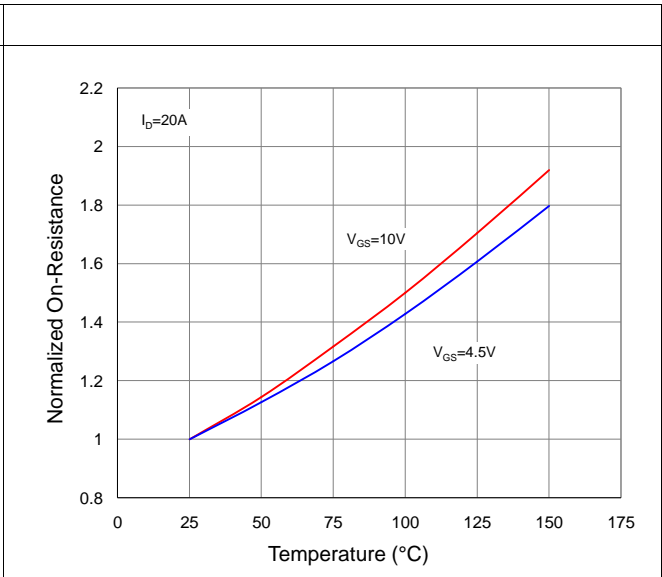
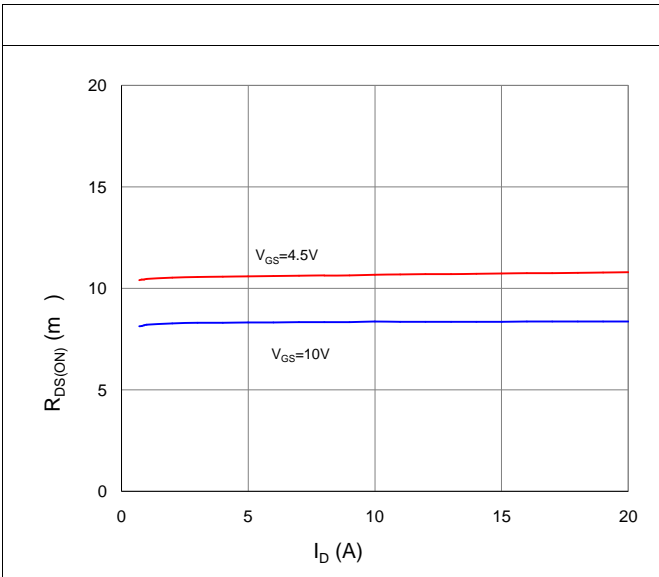
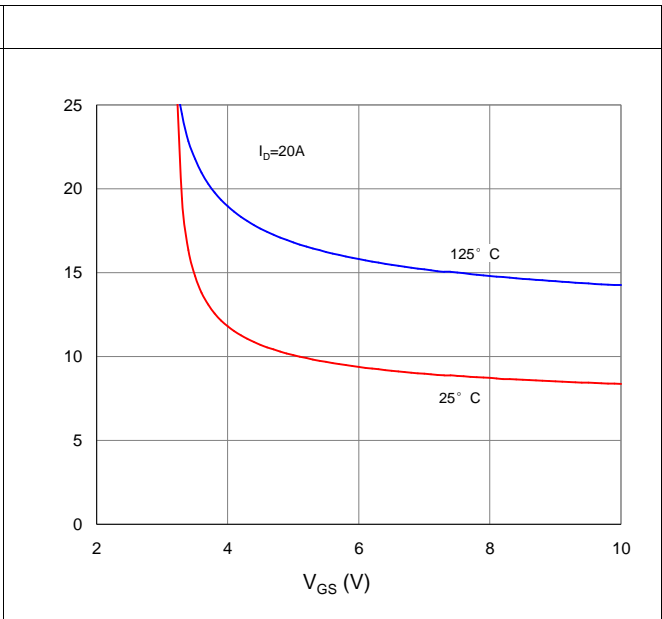
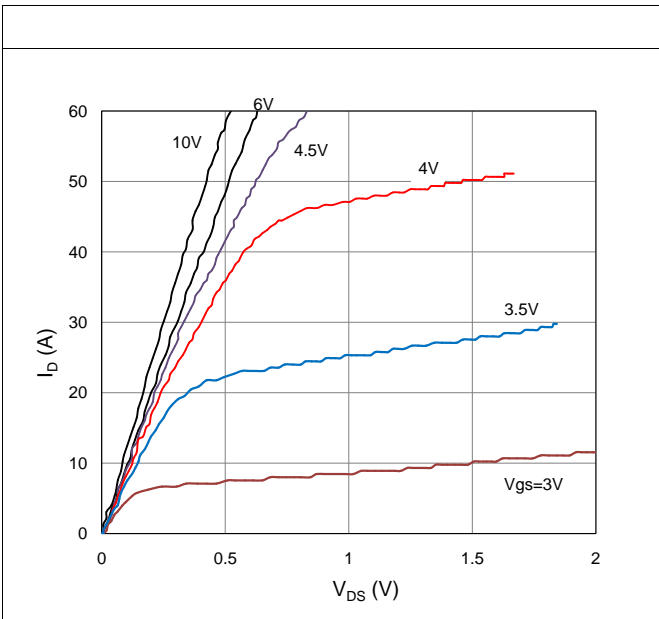
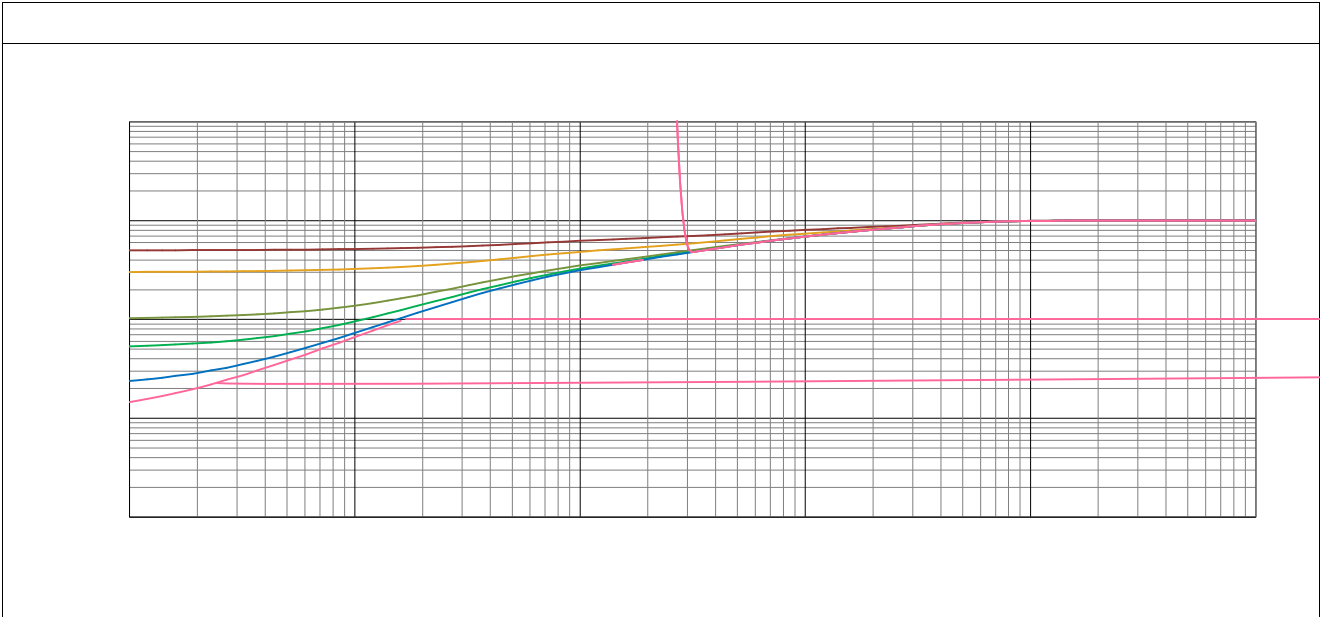
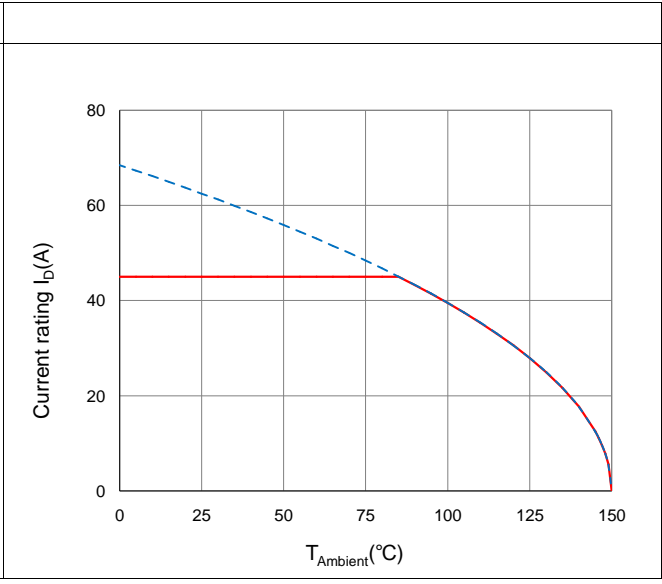
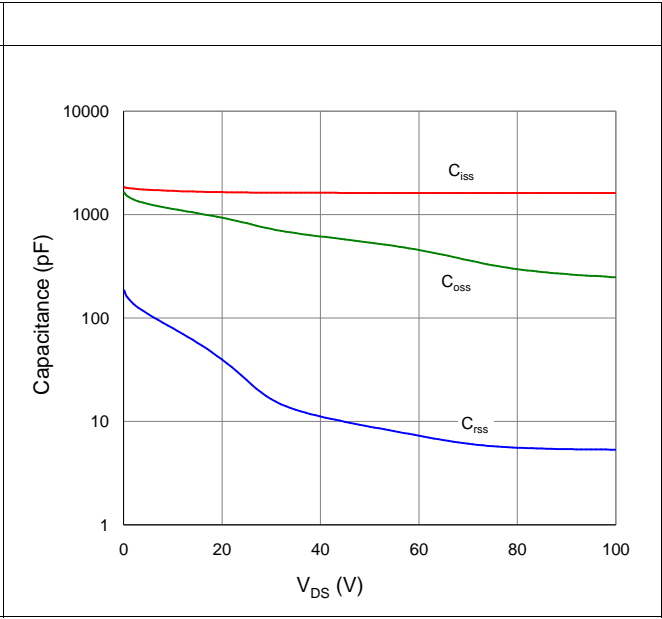
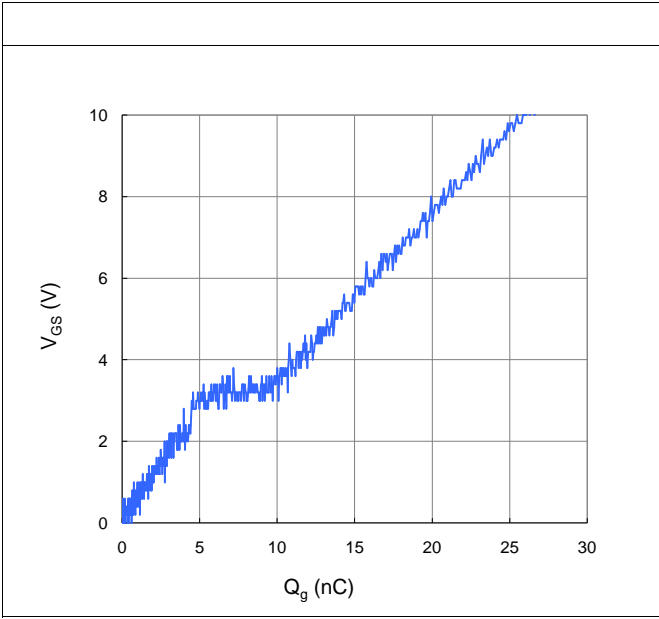
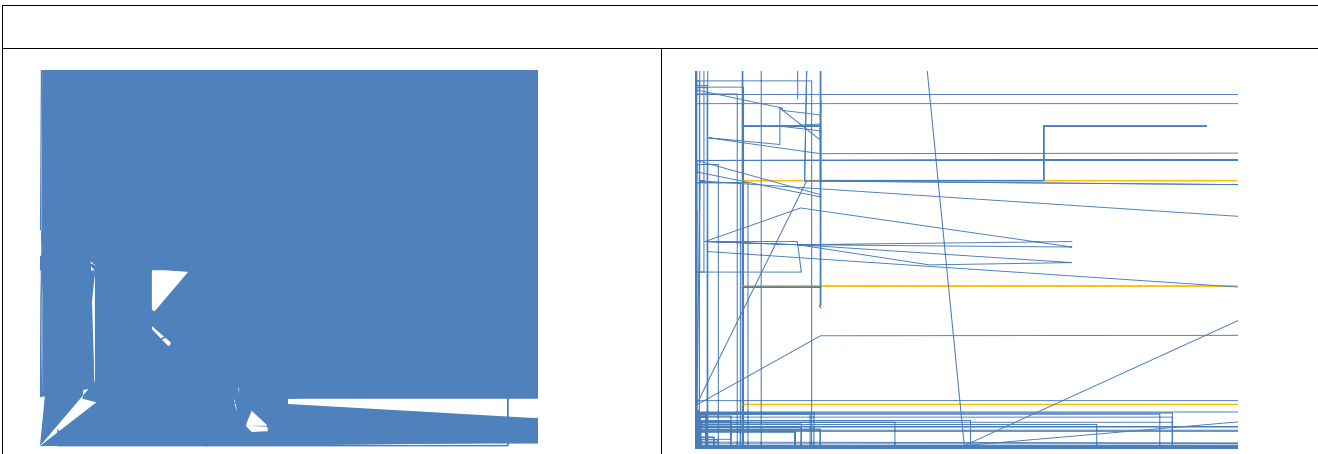
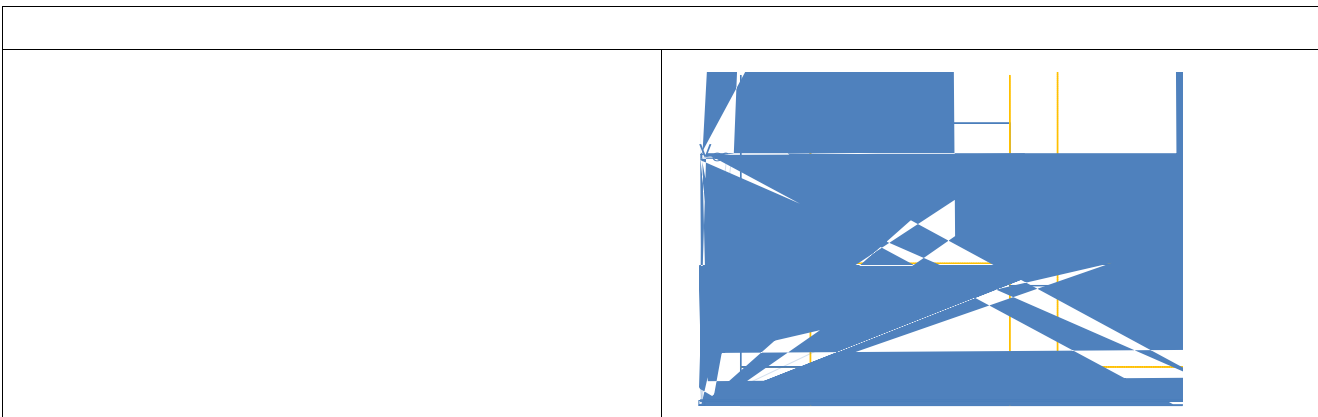
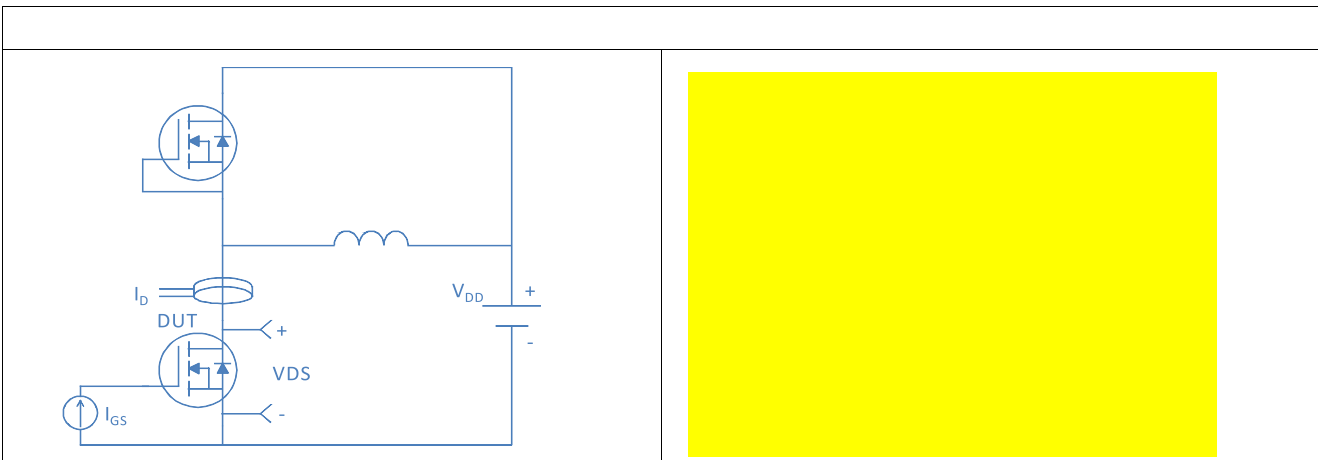
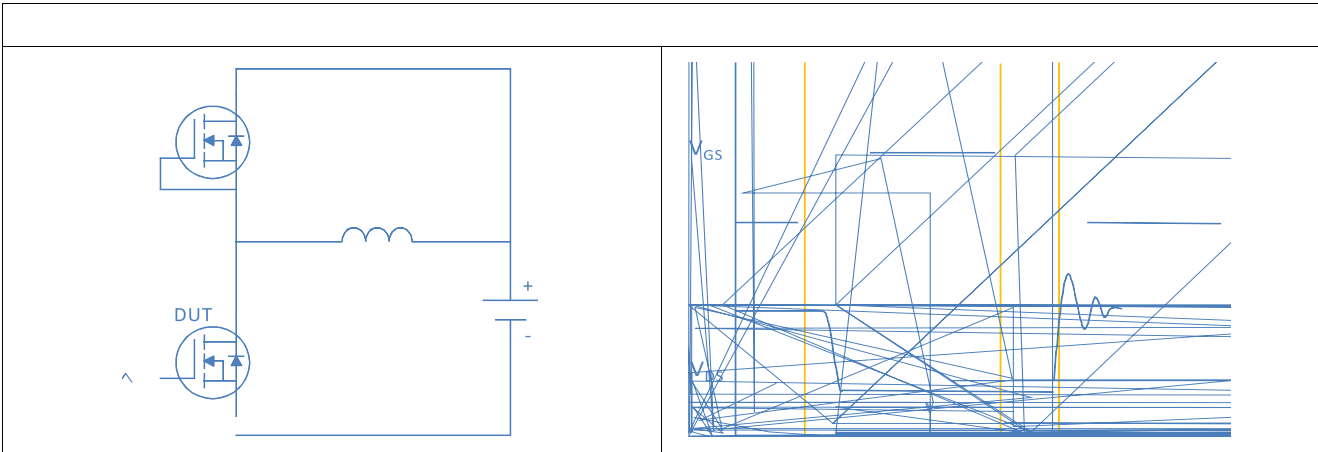

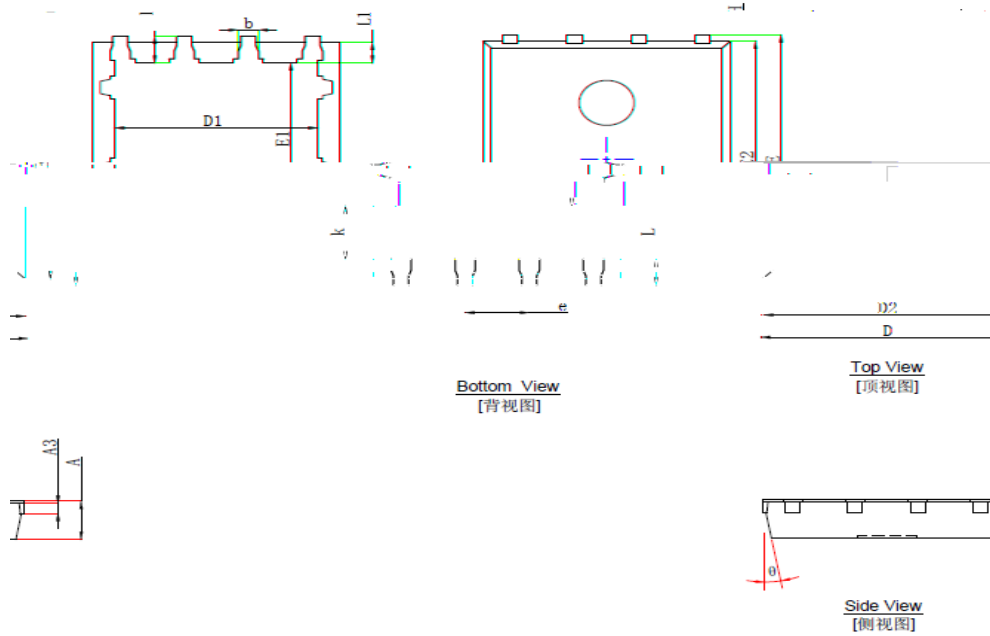

Symbol	Dimensions In Millimeters		Dimensions In Inches	
	Symbol	Value	Symbol	Value
	$\phi 500$	500	$\phi 19.685$	19.685
	$\phi 300$	300	$\phi 11.811$	11.811
	400	400	15.748	15.748
	200	200	7.874	7.874
	400	400	15.748	15.748
	200	200	7.874	7.874
	100	100	3.937	3.937
	200	200	7.874	7.874
	RESERVE		RESERVE	
	$\phi 20$	20	$\phi 0.787$	0.787
	$\phi 18$	18	$\phi 0.709$	0.709
	$\phi 16$	16	$\phi 0.631$	0.631